

HZJD-2 Non-Automatic Oil Drain Dielectric loss And Resistivity Tester



Dear user:

Thank you for choosing HZJD-2 non-automatic oil discharge dielectric loss and resistivity tester.

We hope that this instrument will make your work more relaxed and enjoyable, and make you feel office automation in your test and analysis work.

Before using the instrument, please read this manual, and operate and maintain the instrument according to the manual to extend its service life.

"Just press lightly, the test will be completed automatically" is the operating characteristic of this instrument.

If you are satisfied with this instrument, please tell your colleagues; if you are dissatisfied with this instrument, please call **(0312) 6775656** and tell us-Baoding Huazheng Electric Manufacturing Co., Ltd., our company will definitely satisfy you!

Contents

I. Overview.....	1
II. The Main Functions and Features.....	1
III. Major Technical Indicators.....	2
IV. Use Condition.....	3
V. Panel Description and Operation Matters Needing Attention.....	3
VI. Operation Approach.....	5
VII. the introduction of oil cup.....	10
VIII. Common faults.....	13

I. Overview

HZJD-2 Non-Automatic Oil Drain Dielectric loss And Resistivity Tester, is designed and manufactured based on GB/T5654-2007 of 《Liquid insulating material of relative permittivity, dielectric loss factor and DC resistivity measurements》. It is used for measuring dielectric dissipation factor and DC resistivity of insulating oil and other insulating liquids. The instrument is characterized by integrated structure, and integrates test cell, temperature controller, temperature sensor, dielectric loss test bridge, AC test power, standard capacitor, high resistance meter, DC high voltage source and other major components. The instrument adopts full digital technology and all of the intelligent automatic measurement, is equipped with large color screen (800*480) LCD display, which each step has prompted the Chinese, the test results can be automatically stored and printed output, so that the operator without professional training will be able to use it proficiently.

II. The Main Functions and Features

- 1.The test cell used of the three-electrode structure in line with the national standard GB/T5654-2007, with electrode spacing 2mm, can eliminate the effects of the stray capacitance and leakage on dielectric loss test results. The apparatus is equipped with the oil drainage solenoid switch, and we can empty the test cell in case of not removing it and rinse it with the test sample.
- 2.The instrument adopts the medium frequency induction heating, PID temperature control algorithm. This heating method has the advantages of non-contact between the test cell and the heating body, even heating, fast speed, convenient control, strict control of the temperature within error range of the preset temperature.
- 3.Internal standard capacitor is SF6 gas-filled three-electrode capacitance, and its capacitor dielectric loss and electrical capacity is independent of ambient temperature, humidity and other effects, so that the instrument accuracy can be ensured even after prolonged use.
- 4.AC test power supply using AC-DC-AC conversion, effectively avoid the fluctuations in mains voltage and frequency on dielectric loss measurement accuracy effect. Even a generator, the instrument can work properly.
- 5.Perfect protection function; When there is over voltage、over current or high-voltage short circuit, instruments can quickly cut off pressure, and issues a warning message. When the temperature of the sensor failure or not connected, the instrument will also issue a warning message.
- 6.There is a temperature limiting relay in the medium frequency induction heating furnace. When temperature above 120 degrees, the instrument frees the relay and stops heating.

7. More convenient the experimental parameter is set. Temperature setting range 0~120℃, AC voltage setting range 500~2000V, DC voltage setting range 300~500V.

8. Using of large-screen LCD display, with backlight and clear display. Friendly interface, simply follow the Chinese menu prompt, enter the command, the instrument can be automatically tested. And automatically store and print test results.

9. Built-in real-time clock, the test date and time may be saved, displayed and printed with the test results.

10. Calibration functions of cleaned dry cell. The measurement of dry cell's capacitance and dielectric loss factor can determine its cleaning and assembly conditions. The calibration data is automatically saved and so that it facilitates the calculation of relative permittivity and DC resistivity.

III. Major Technical Indicators

Voltage supply: AC 220V±10%

Power frequency: 50Hz/60Hz ±1%

Measuring range:

Electric capacity 5pF~200pF

Relative Permittivity 1.000~30.000

Dielectric loss factor 0.00001~100

DC Resistivity 2.5MΩm~20TΩm

Measuring accuracy:

Electric capacity ± (1% of measured value+0.5pF)

Relative Permittivity ±1% of measured value

Dielectric dissipation factor ± (1% of measured value+0.0001)

DC Resistivity ±10% of measured value

Resolution:

Electric capacity 0.01pF

Relative capacitivity 0.001

Dielectric dissipation factor 0.00001

Measured temperature range: 0~120℃

Temperature measurement error: ±0.5℃

Test Voltage AC(RMS): 500~2000V Continuously adjustable, frequency 50Hz

Test Voltage DC: 300~500V Continuously adjustable

Power consumption: 100W

External dimensions: 500×360×420

Total weight: 22Kg

IV. Use Condition

Ambient temperature: 0℃~40℃

Relative humidity(RH): <75%

V. Panel Description and Operation Matters Needing Attention

1. Panel description

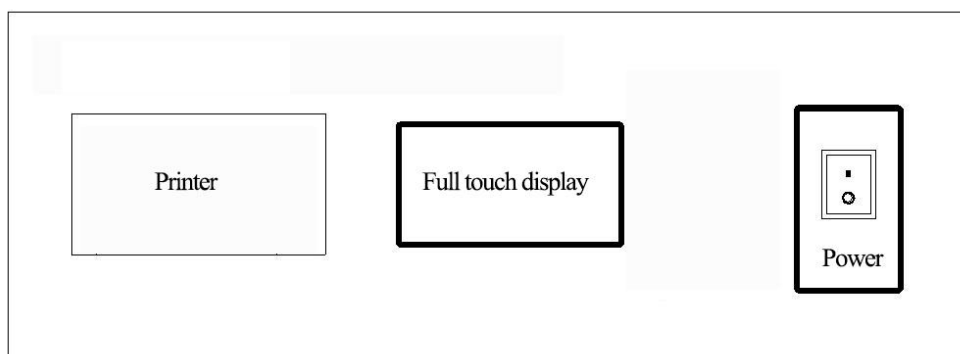

Fig.1 Operating Panel

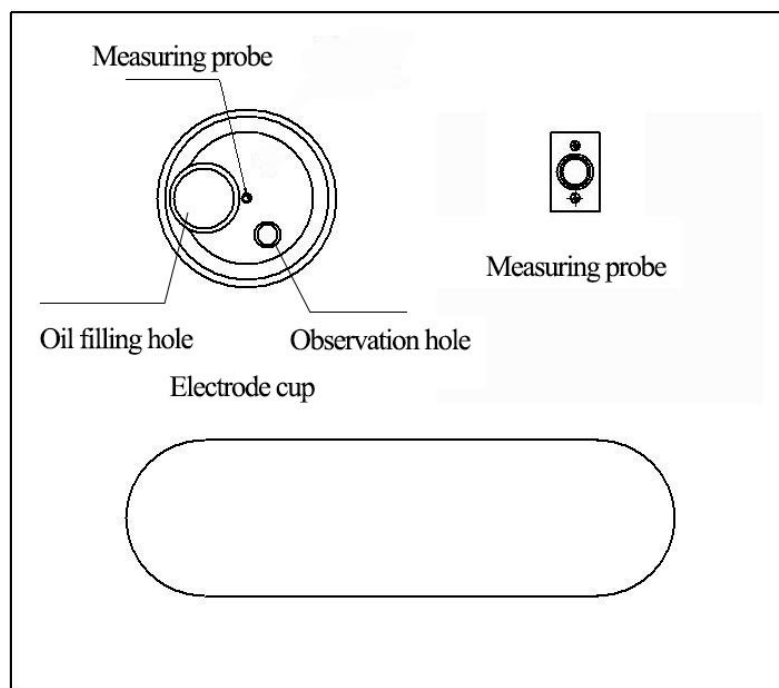

Fig.2 Top panel

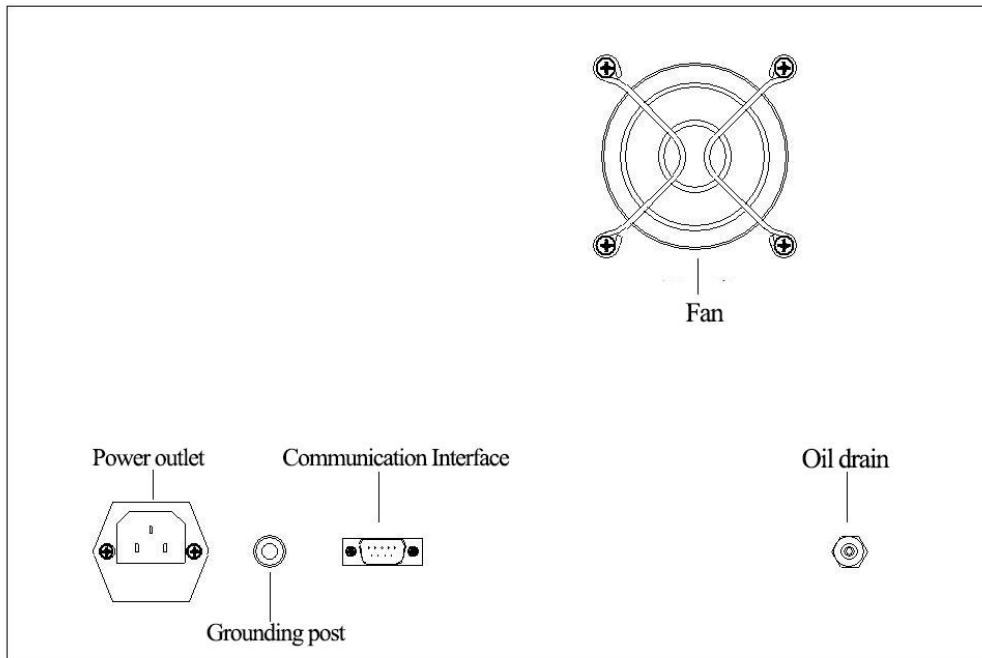

Fig.3 Back panel

2. Instrument operating instructions and matters needing attention

- (1)The instrument must be reliable grounding, power entrance lead into AC220V power.
- (2)Open tank cover, and take out the test cell, we should shut the tank cover, when heating and testing the dielectric loss.
- (3)The cover is protective and when you open it, will interrupt the heating and high pressure.
- (4)During the test, there is high pressure and high temperature. Do not contact the test cell, cable and socket when the power is electrify and testing.
- (5)Take care in order to avoid sprinkling the oil into the slot of test cell and the top panel when injecting and discharging oil.
- (6)If it appears dead stop faults phenomenon while testing, turn the system back on, and restart the instrument.

Use the appropriate power supply cables.

Only use the product-specific power supply line in accordance with the product specification. Be right to disconnect and connect.

The instrument must be adequately grounded.

In addition to the power line grounding conductor grounding, product shell's grounding columns must be grounded

In order to prevent electric shock, the grounding conductor must be connected with the ground.

Before connecting with the input or output terminals of the product, make sure that the

product is properly grounded.

Note that rating value of all terminals.

To prevent fire or electric shock hazard, please note that all rating values and markings in the product.

Before connecting this product, please read the product manual in order to further understand the information about rating values.

Use the appropriate protective tube.

Use only the protective tube in accordance with provisions of this product type and rating.

Do not operate when there is any suspicion of failure. If you suspect this product is damaged, please contact our repair staff to check, and do not continue the boot operation.

Align the locating slot when the internal electrode into the external electrode.

Do not operate in humid environments.

Do not operate in explosive environments.

Keep the surface clean and dry.

Special notice: This instrument has high voltage output, improper use can compromise personal safety, prior to the use of this instrument, be sure to read the instruction manual carefully!

VI.Operation Approach

1、 Place the cleaned test cell in the groove, and connect the test cable as shown in Fig.2.

2、 Start the instrument.

Turn on the power switch, and the LCD displays the main menu as shown in Fig.4.

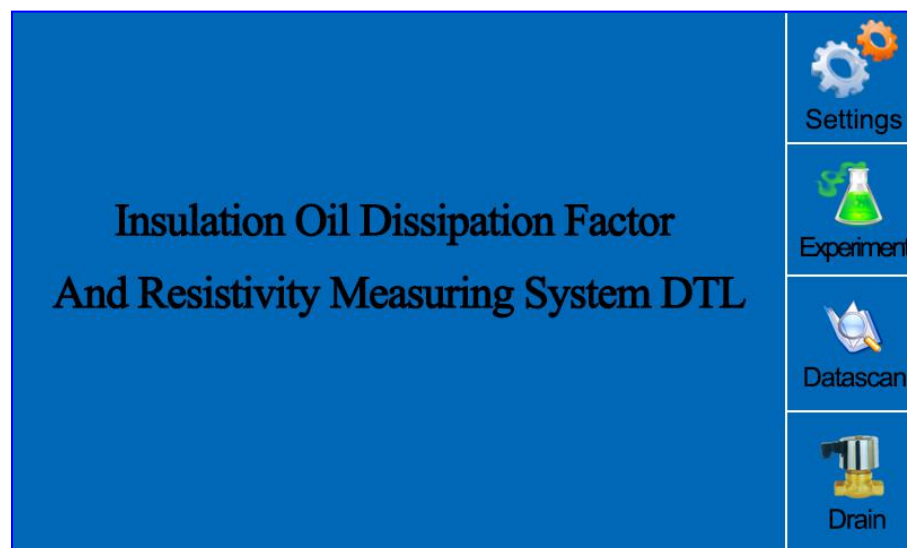

Fig.4

3、 Test Conditions

Enter "Test Conditions" parameter settings screen as shown in Fig.5.

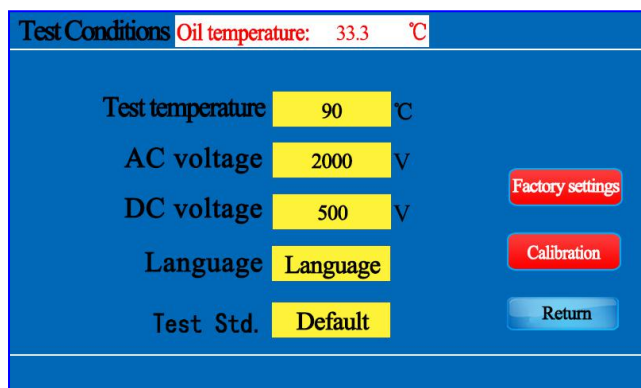

Fig.5

① Parameter range: Temperature: 0~120℃

AC Voltage: 500~2000V

DC Voltage: 300~500V

② Method for setting parameters

Tap the display position and enter the parameters you want to set.

Tap the [Return] key, the instrument saves the set parameters and returns to the main menu. The power-on instrument retains the last set parameters and does not need to be reset.

③ Automatic print

Tap [Automatic Print] to turn automatic print on or off. If automatic printing is turned on, the printer automatically prints the test results after each test is completed.

④ time setting

The system clock can be corrected by tapping the time.

4、 Dry Cell Calibration

Before entering the calibration, make sure that the test oil cup in the cup position is an oil-free empty oil cup, and connect the test cable and temperature probe cable. Tap the [Dry cell calibration] button to enter the calibration screen as shown in Fig.6, tap the [Start] button to perform the empty cup calibration test.

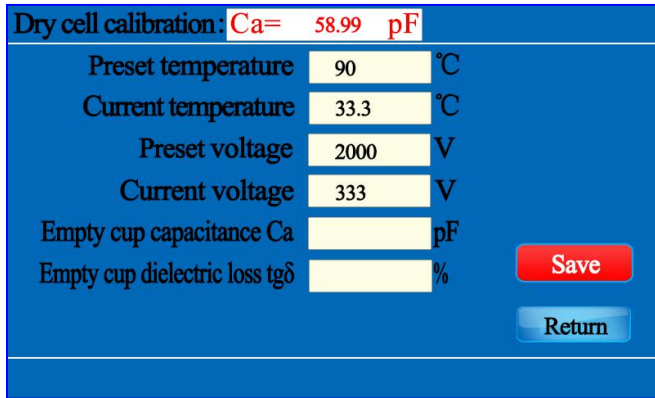

Fig.6

① Since the temperature has no significant effect on the capacitance and dielectric loss factor of the air-filled electrode cup, a lower test temperature can be set. It is recommended to set the temperature to 10°C above room temperature. Tap the [Return] button to return to the main menu.

② Calibration result----After the empty cup calibration measurement is completed, the calibration result is displayed in the screen of Fig. 7. At this time, tap the [Save] button to save the calibration result, and tap the [Return] button to return to the main menu.

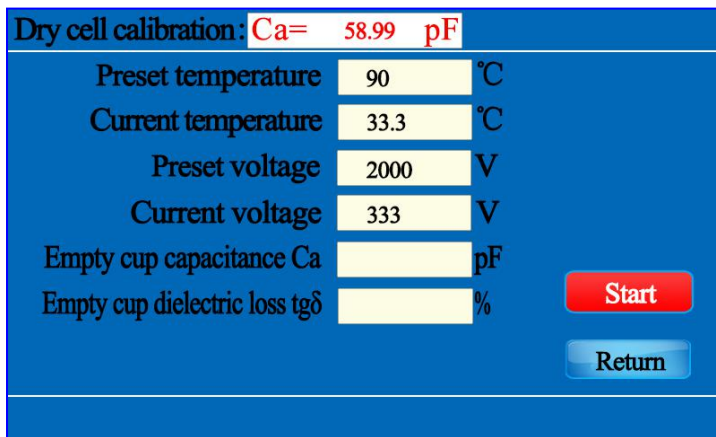

Fig.7

5、 Automatic measurement

Before entering the automatic measurement, make sure that the oil cup is filled with oil and that the test cable is connected. Tap [Test] on the main interface to enter the automatic measurement screen, as shown in Fig.8.

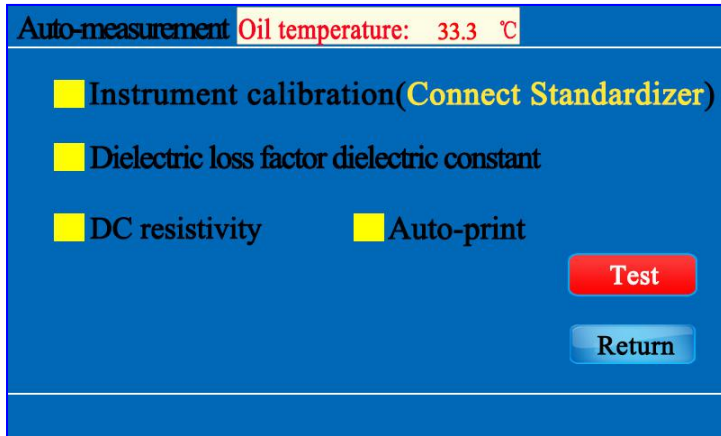

Fig.8

As shown in the above picture, there are 2 options. Tap the [dielectric loss factor dielectric constant] button to turn the dielectric loss factor test on/off. Tap the [DC Resistivity] button to turn the DC resistivity test on/off. After selecting it, tap the [Test] button, the instrument will automatically complete the selected test item, and the experiment can be suspended or canceled during the test.

① Dielectric loss factor dielectric constant screen is shown in figure 9-1:

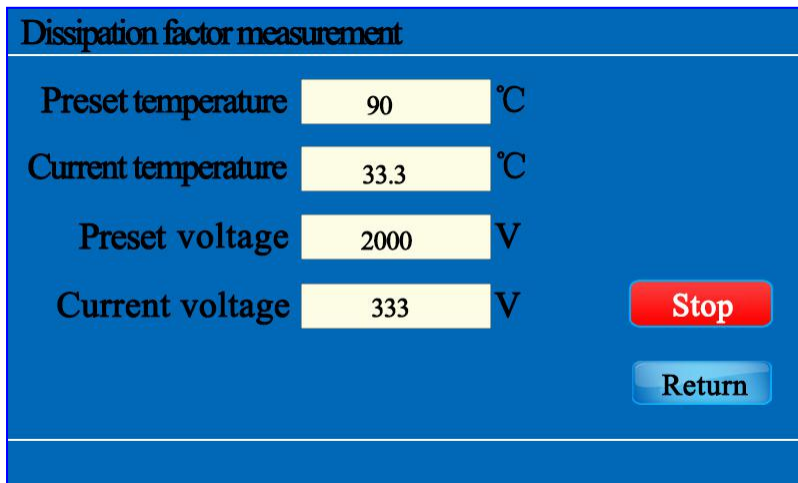

Fig.9-1

② DC resistivity screen is shown in Figure 9-2:

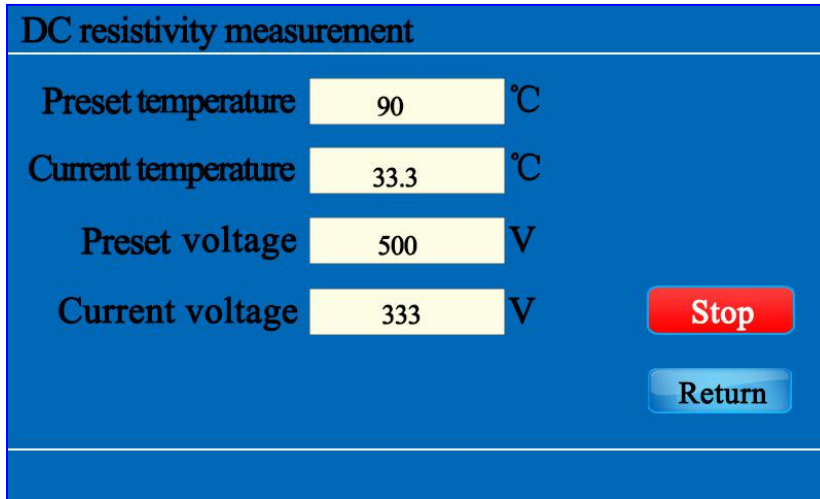

Fig.9-2

③Test Results----After the test is over, the test results are displayed in the screen shown in Figure 10.If the automatic print item is selected earlier, the printer automatically prints the test result.If there is no automatic print item selected, tap the [Print] button and the printer will print the displayed test result.Tap the [Return] button to return to the main menu.

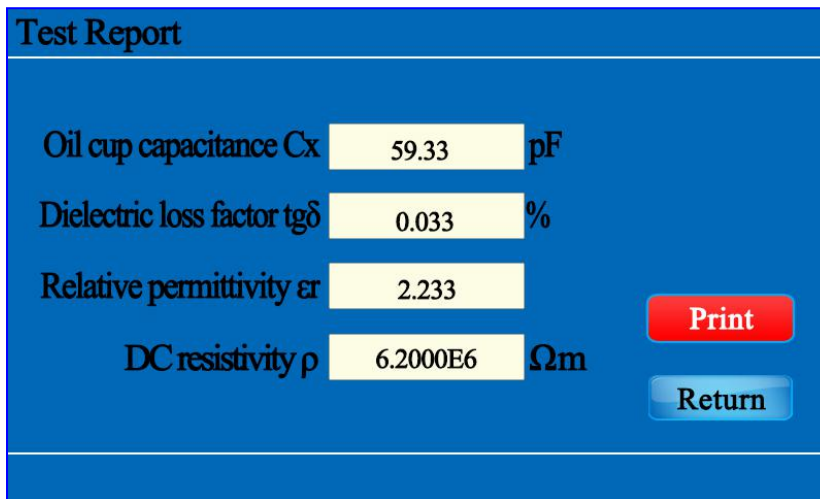

Fig.10

6、Datascan

In the main interface, tap the [Datascan] button to enter the datascan screen as shown in Figure 11.

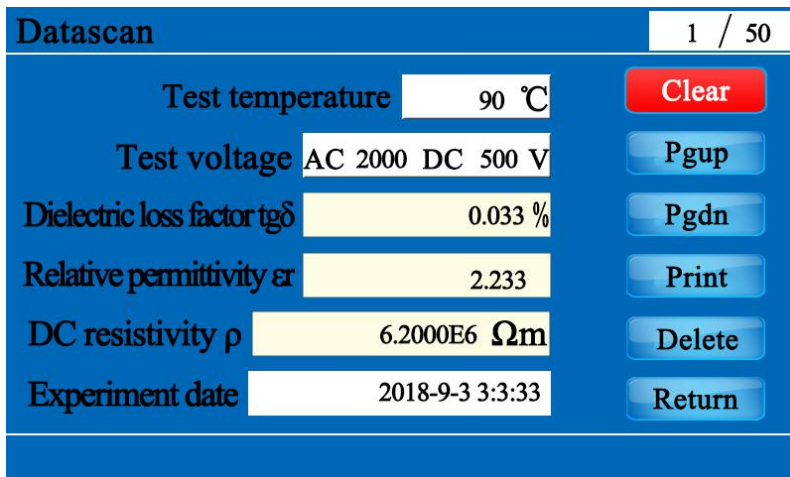

Fig.11

The instrument screen displays the total number of pages and the current number of pages, up to 100 pages. Tap the [PgUp] and [PgDn] buttons to page up and down. Tap the [Delete] button to delete the data of the currently displayed page. Tap the [Print] button to print the current page data. Tap the clear button in the upper left corner to clear all test records, and tap the [Return] button to return to the main menu.

7、 Oil drain control

In the main interface, tap the [Drain] button to enter the oil drain screen as shown in Figure 12.

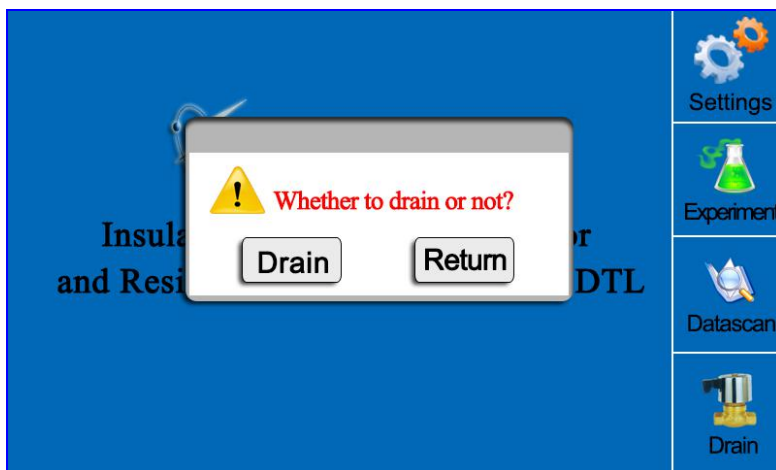

Fig.12

Tap the [Drain] button to drain the oil, and tap the [Return] button to stop the drain and back to the main interface!

VII. the introduction of oil cup

1、 Oil cup structure

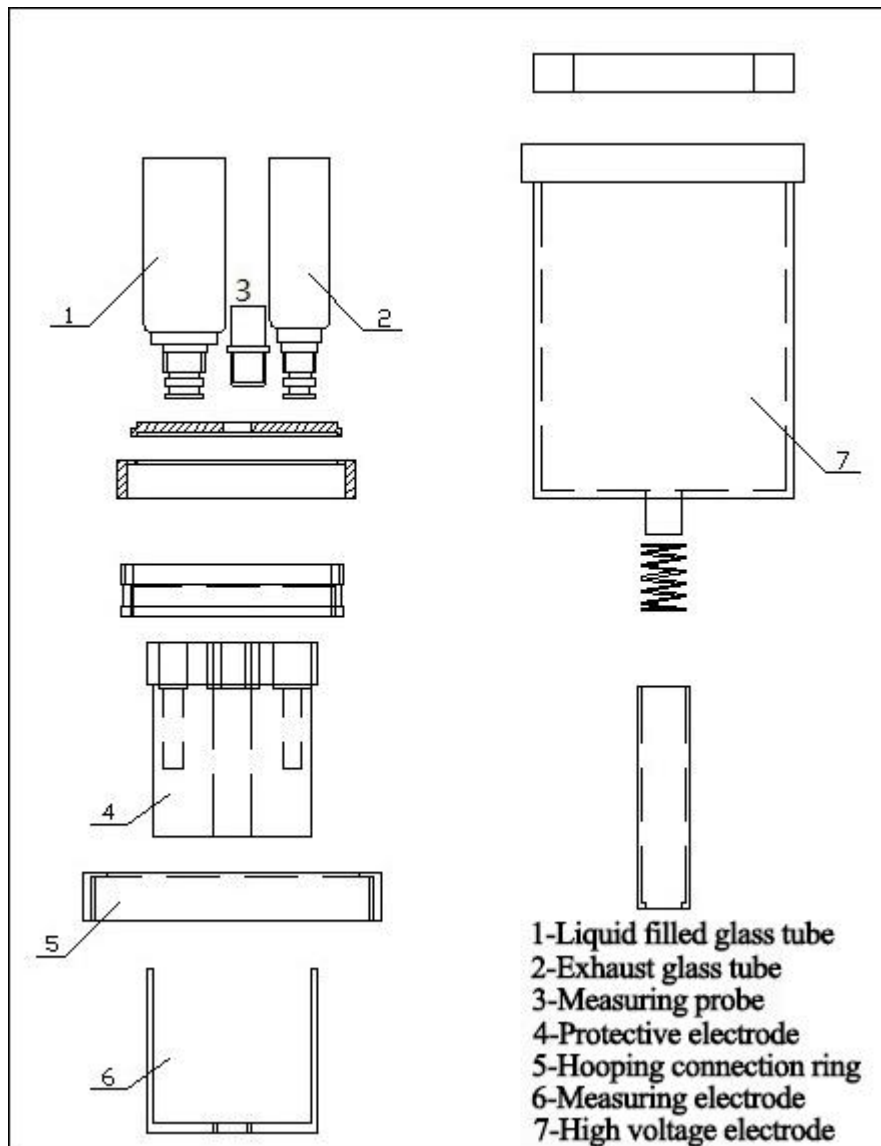

Fig.13 Oil cup schematic

Numbers 1 to 7 in Figure 12 are assembled at the factory and are collectively referred to as "internal electrodes". Disassemble the oil cup in accordance with Article 4 of this chapter only when it is necessary to disassemble and clean the oil cup. The inner and outer electrodes have positioning grooves and positioning posts to be aligned.

2、oil cup technical standards

The test cell used of three-electrode structure in line with the national standard of GB/T5654-2007, with electrode gap spacing 2mm, can eliminate the effects of stray capacitance and reducing leakage on the dielectric loss test results.

- (1) Distance between high voltage and low voltage 2mm
- (2) Dry cell capacitance $60 \pm 5 \text{PF}$
- (3) Maximum test voltage (power frequency) 2000V
- (4) Dry cell dielectric loss $\tan \delta < 1 \times 10^{-4}$
- (5) Liquid capacity about 40ml

(6) Electrode material Stainless steel

(7) Volume 70mm (D) × 120mm (H)

3、 Loading and taking out the test cell

(1) Loading the test cell: Put the oil cup into the instrument furnace smoothly, ensure that the bottom contact of the oil cup is good, and then connect the test line, the test probe is inserted into the test sample cup.

(2) Taking out the test cell: After the test line is removed, the oil cup can be taken out..

4、 Dismantling and assembling the test cell's electrode

The inner electrode can be removed directly from the oil cup

Attention: Inner electrode is very precision components, when you take out and load it, actions must be slow and steady. Do not collide between the internal and external electrode in case of damaging the surface and causing the entire test cell scrapped.

5、 Loading oil sample

Remove the inner electrode, pour the oil sample 40mL into the oil cup, and take care not to entrap bubbles in the oil as much as possible.

The inner electrode is then loaded into the oil cup and needs to be stationary for more than 15 minutes so that the bubbles can be completely discharged before testing.

Try.

6、 Cleaning the test cell

This step is important for the cleaning of the oil cup before measurement. Because insulating oil has a very sensitive reaction to very small pollution. The following methodological elements must therefore be strictly followed.

Method 1:

- (1) Complete removal of oil cup electrodes;
- (2) Wash with neutral soap or detergent. Abrasive particles and friction actions should not damage the electrode surface;
- (3) Wash the electrodes several times with clean water;
- (4) Soak parts with anhydrous alcohol;
- (5) After the electrode is cleaned, the surfaces of the electrode components are cleaned with silk fabrics, and care is taken to place the parts in a clean container without contamination of the surface with dust and moisture;
- (6) Place the parts in an oven around 100 °C and dry them.

Method 2:

- (1) Take the electrode cup apart(see the diagram of the oil cup).
- (2) Thoroughly cleaning all parts of the oil cup with chemically pure petroleum ether and benzene.

(3) Wash the oil cup again with acetone, and then rinse it with neutral detergent.

Use 5 % sodium phosphate distilled water solution to boil for 5 minutes, and then wash with distilled water several times.

Wash all parts several times with distilled water.

(6) Dry the parts in an oven with a temperature of 105 to 110 °C for 60 to 90 minutes.

(7) After the parts are washed, they are assembled when the temperature drops to room temperature.

Method 3: Ultrasonic cleaning method

(1) Open the oil cup.

(2) Wash all parts with solvent.

(3) Using soapy water to oscillate all parts for 20 minutes in an ultrasonic cleaner; Remove parts, with tap water and distilled water cleaning; We're oscillating with distilled water for 20 minutes.

Method 4: Solvent cleaning method

(1) Open the oil cup.

(2) Rinse all parts with a solvent and replace the secondary solvent.

(3) Wash all parts with acetone first and then with tap water. Then wash with distilled water.

(4) Dry the parts in an oven with a temperature of 105 to 110 °C for 60 to 90 minutes.

When testing a group of similar liquid samples but not used, we can use the same test cell which doesn't need intermediate washing, as long as the last test sample has better performance than the specified value of the measuring,. If the performance of the tested sample is inferior to the measuring sample, the test cell must be cleaned before you make the next test.

VIII.Common faults

1. The screen displays "electrode cup short circuit"

Answer: First check whether the positioning grooves of the inner electrode and the outer electrode are aligned, and then check the "inner electrode"

Whether the installation is loose, the main reason is whether the 7 in Figure 12 is loose.

2. The screen displays "Please perform [Empty Cup Calibration]"

Answer: When the capacitance value of the empty cup is not within the range of $60\pm 5\text{pF}$, empty cup calibration is required; ①The inner and outer electrodes of the oil cup are not placed or the inner electrodes are not assembled, and there is discharge phenomenon;

②The oil cup is not clean, the inner and outer electrodes There are impurities that need to be cleaned.

3. After the buzzer sounds 5 times, the instrument returns to the startup interface.

Answer: ①Check whether the capacitance value of the empty cup is within the range of

60±5pF, ②Check whether the oil cup is placed

Good, whether there is discharge phenomenon.

4. What should I do when the units place of the set voltage parameter is not zero?

Answer: Use the [decrease] key to minimize the set voltage value, and then use the [increase] key to adjust.